

Complete Protection

FOR CHALLENGING ENVIRONMENTS



Who We Are



We are OvoGard™: suppliers of innovative shields that protect essential infrastructure in secure and often demanding environments.

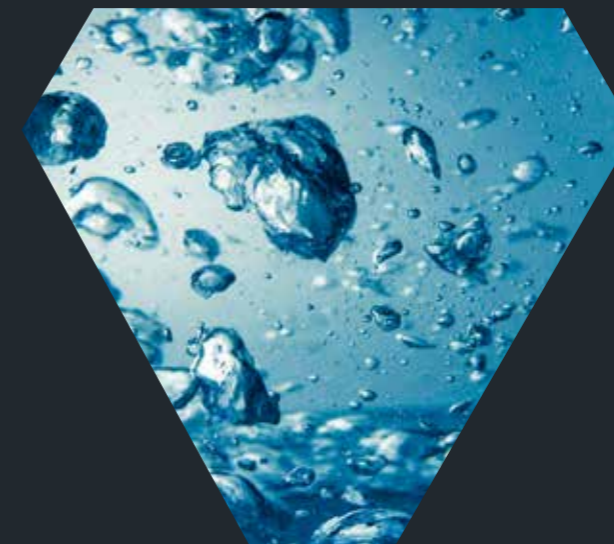

We use decades of experience working with secure facilities to provide solutions that work for all users without compromising on safety or quality. Virtually indestructible and including a range of enhanced safety features, our shields offer a vital layer of defense, protecting essential infrastructure from the risks of theft, vandalism and unauthorised access.

Our bespoke designs secure your investments whilst allowing free and unfettered access. OvoGard's shield products can be used to secure installations including:

- **Water coolers**
- **Boiler systems**
- **Firefighting equipment**
- **Waste bins**

Our customer commitment doesn't end there. Whilst we can protect your installations with our virtually indestructible shields, we also supply all of the products you'll need in between, such as drinking water refills, fire extinguishers, bins, boilers and hot water tap systems. Keep reading to learn more!



Our Products & Services



SecuraFlo™ Protective Shield

SecuraFlo™ is a virtually indestructible shield that secures water cooler units. Suitable for use in challenging and often hostile settings, our durable solution offers anti-climb, anti-ligature and anti-stash features that allow you to offer hydration solutions with as little risk as possible.



SecuraBin™ Protective Shield

SecuraBin™ is a virtually indestructible anti-stash bin cover that provides protection for a standard 50 litre internal bin helping to guard against fire and other associated risks.



SecuraFire™ Protective Shield

The SecuraFire™ cover is a virtually indestructible lockable shield that provides fire extinguishers and other firefighting equipment with strong protection against vandalism, theft, tampering, climbing and all unauthorised access.



SecuraBoil™ Advanced Boiler & Hot Water System Maintenance

OvoGard™ specialises in providing safe access to hot water systems, significantly reducing the risk of accident or injury by scalding. Ideal for healthcare environments and other challenging areas like prisons and custodial areas, the SecuraBoil™ service protects staff & service users from being scalded by temperature-adjustable boilers, with our advanced maintenance service eliminating the risk of scalding by non-compliant or defunct equipment.

Boiler & Hot Water Tap Supplies

As approved and certified ZIP supply partners, we repair, replace and supply brand new boiler and hot tap system units and their components. Part replacements are available at a typically cost-effective rate. Where modified, personalised systems are required, the OvoGard™ team can work with site architects to follow orders through until completion.

SecuraFlo™

Guaranteed Protection for Water Coolers & Hydration Systems

- SAPPHIRE**
RAL 5015
- BYZANTINE**
RAL 4006
- OLIVE**
RAL 6021

- Mental Healthcare
- Law Enforcement
- Education
- Acute Healthcare



Water coolers, hot water systems and other hydration solutions can represent significant investments; with repair & maintenance work often coming at a heavy cost. SecuraFlo™ protects your investment the smart way.

SecuraFlo™ is an innovative shield that acts as protective housing for water coolers and other essential infrastructure in secure, often challenging environments.

We understand that user safety is of paramount importance in secure settings: that's why we've engineered this virtually indestructible solution to give end users independence whilst prioritising their health and welfare.

SecuraFlo™ is a cost-effective measure to ensure all users have safe and independent access to water resources. Equipped with tamper-proof connections between both the casing & the sidewall as well as the casing & the cooler, our durable shield prevents moving or adaptation by users who are not qualified to do so. Providing an anti-climb, anti-ligature design, our solution prevents users from harming themselves or others.

Protecting users:

This product is suitable for use across a range of environments which accommodate some of the most vulnerable in society, including hospital wards, mental health settings, nursing homes and secure medical areas. SecuraFlo™ ensures that all service users have free access to water supply in a way that protects them from accident or injury. Antimicrobial protection is available for added security in environments where hygiene is critical.

Protecting investments:

Water supplies represent a significant investment. Whether you've decided to install a cold water supply or a hot water dispenser, these additions to your organisation can cost an average of £150-1,000 depending on the range of features available. The SecuraFlo™ shield can protect your investment and eliminate unwanted repair and replacement costs.

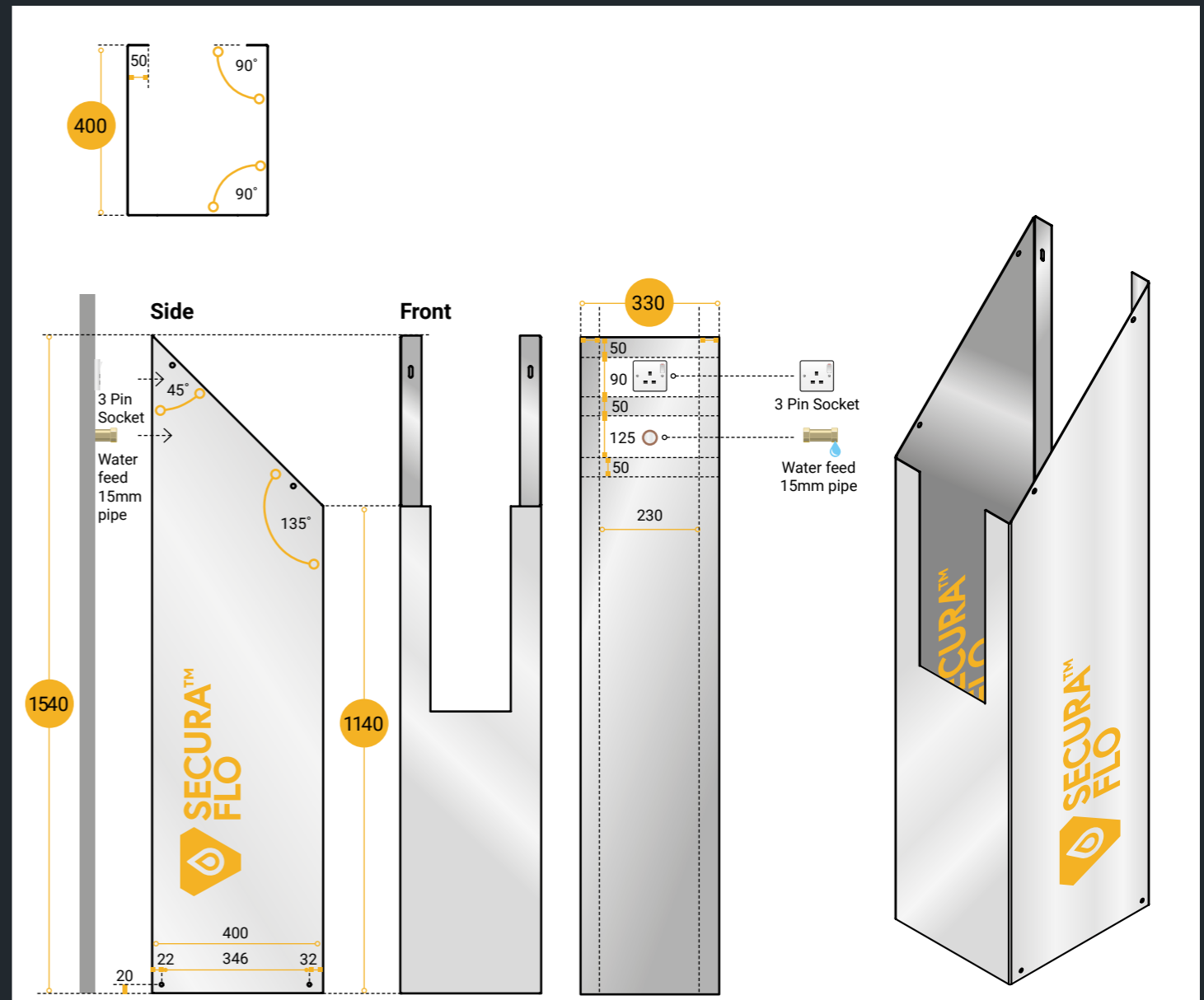

Height (mm)	1540 - 1140
Depth (mm)	400
Width (mm)	334
Colour	Sapphire (RAL5015), Byzantine (RAL4006) or Olive (RAL6021)
Service Window	1225mm from floor level
Electricity	3-pin socket
Water	15mm mains water supply, preferably terminating in highlighted area

Features

- Patented anti-ligature air vent system
- Durable, anti-climb design
- Anti-ligature construction
- Anti-stash features
- Secure locking system
- Optional antimicrobial protection
- A permanent, cost-effect solution



SecuraFire™



Guaranteed Protection for Firefighting Equipment

- Mental Healthcare
- Education
- Law Enforcement
- Acute Healthcare

- SAPPHIRE RAL 5015
- BYZANTINE RAL 4006
- OLIVE RAL 6021
- BRIGHT RED RAL 3026



The SecuraFire™ cover is a virtually indestructible lockable shield that provides fire extinguishers and other firefighting equipment with strong protection against vandalism, theft, tampering, climbing and all unauthorised access.

This unit comes standard in either 1.5 or 2mm mild powder coated steel or Aluzinc for extra rust protection (alternatively stainless steel).

Ideal for education and healthcare environments:

Fire extinguishers and firefighting equipment are essential in schools and healthcare environments. The SecuraFire™ shroud protects all contents housed inside and prevents any tampering, making it perfect for schools, colleges, mental healthcare institutions, acute healthcare centres and law enforcement.

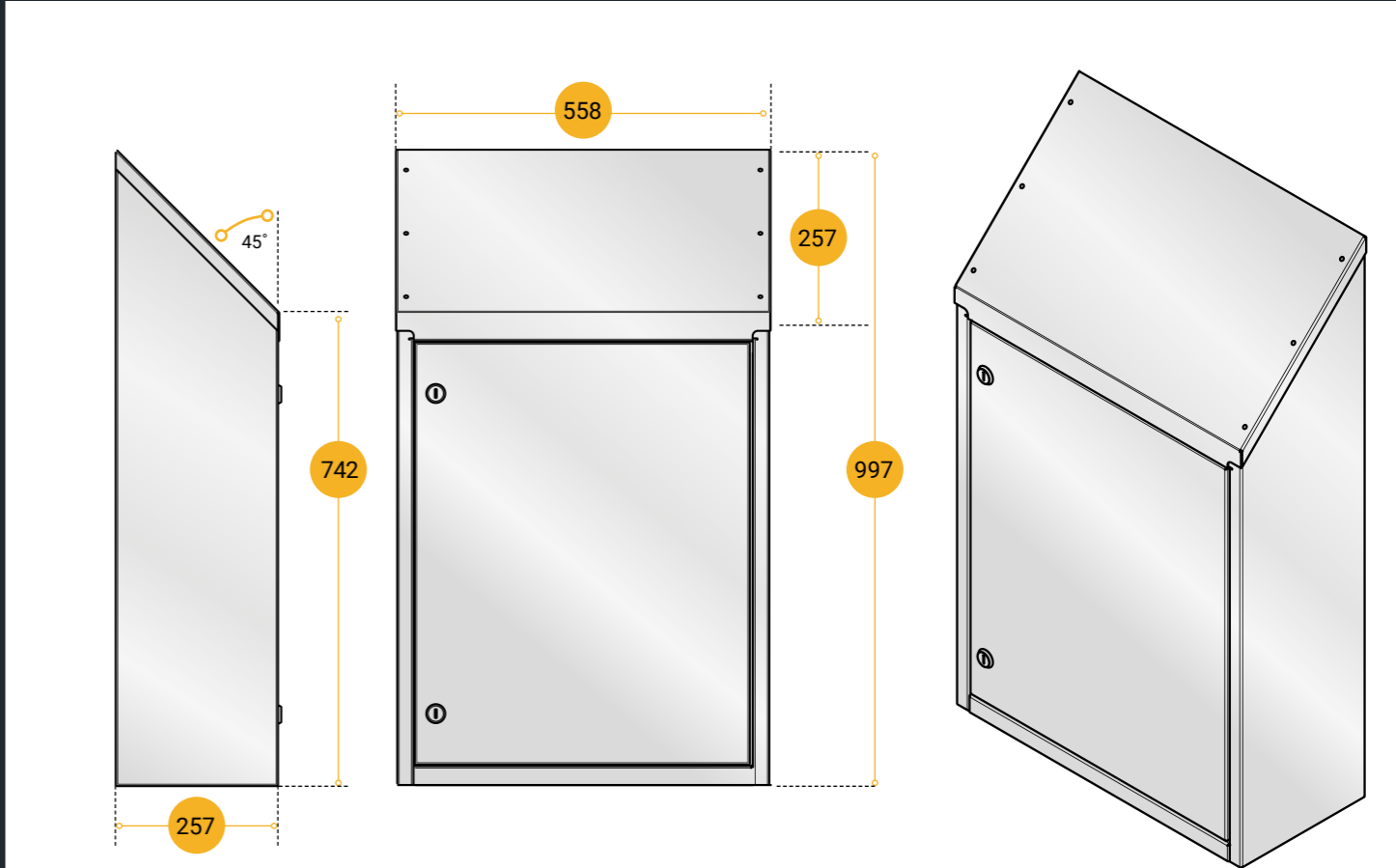
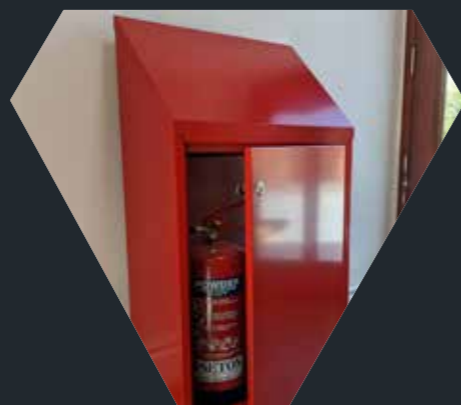

Height (mm)	997
Depth (mm)	257
Width (mm)	588
Colour	Sapphire (RAL5015), Byzantine (RAL4006) Bright Red (RAL3026), Olive (RAL6021) - Specific RAL colour options also available

Features

- Durable, anti-climb design
- Anti-ligature construction
- Anti-stash features
- Secure locking system
- Optional fitted locks
- Optional antimicrobial protection
- A permanent, cost-effect solution



SecuraBin™

Guaranteed Protection for Waste Management

- Mental Healthcare
- Public Spaces
- Law Enforcement
- Acute Healthcare

- SAPPHIRE**
RAL 5015
- BYZANTINE**
RAL 4006
- OLIVE**
RAL 6021



SecuraBin™ is a virtually indestructible anti-stash bin cover that provides protection for a standard 50 litre internal bin helping to guard against fire and other associated risks.

This unit comes standard in either 1.5 or 2mm mild steel powder coated steel or Aluzinc for extra rust protection (alternatively stainless steel).

Ideal for mental and acute healthcare environments:

Waste management tampering in healthcare environments poses a real safety threat. Left unguarded, bins can be used as stashing spots or pose a danger to people accessing discarded contents. This shield provides protection against associated risks and gives staff, patients, and custodians one less thing to worry about.

This product can also be used in open public spaces and law enforcement.

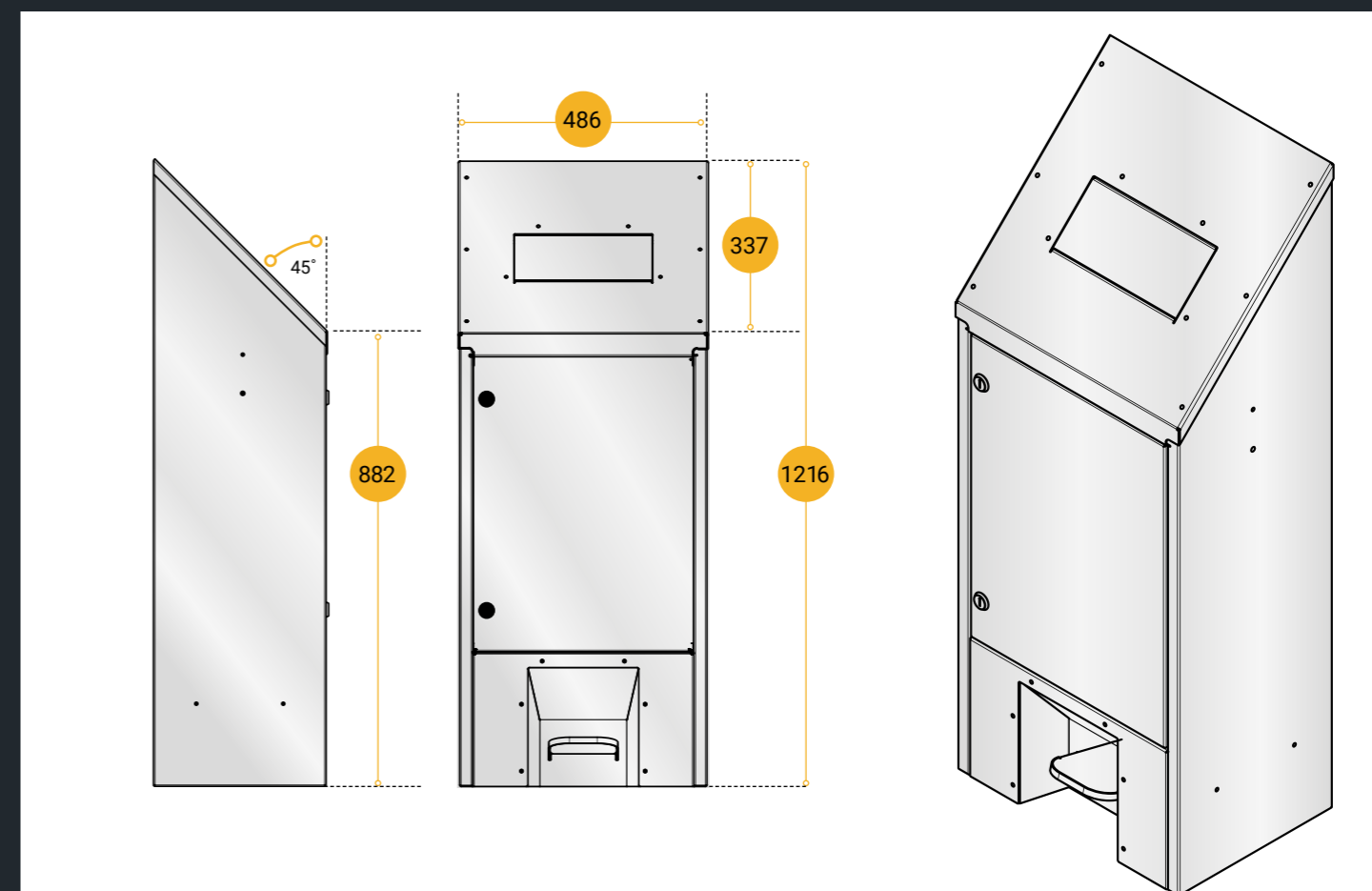

Height (mm)	1216
Depth (mm)	337
Width (mm)	486
Colour	Sapphire (RAL5015), Byzantine (RAL4006) Olive (RAL6021) - Specific RAL colour options also available

Features

- Durable anti-climb design
- Ligature-resistant construction
- Anti-stash internal mechanism
- Secure locking system – designed to incorporate any standard lock barrel
- Optional fitted locks
- Pedal operated lid for enhanced infection control



SecuraBoil™

Advanced Boiler & Hot Water Tap Maintenance and Modification



The SecuraBoil™ Advanced Boiler & Hot Water Tap Maintenance and Modification service guarantees safe access to hot water systems, significantly reducing the risk of accident or injury by scalding.

Ideal for healthcare environments and other challenging areas, the SecuraBoil™ service protects staff & patients from being scalded by temperature-adjustable boilers, with our advanced maintenance service eliminating the risk of scalding by non-compliant or defunct equipment.

Maintenance & modification: OvoGard™ is proud to provide a high level of skill around the maintenance of boiler and hot water tap systems, as well as any modifications to suit your operational needs. This includes system sanitisation; changing of filters, limescale management and refrigeration repairs. For customers working in healthcare and other challenging environments, we're also skilled in modifying systems for safe delivery of water supplies, including boiling safety lock option for the safe delivery of water for hot drinks.

System troubleshooting:

Whether your ZIP boiler or hot water system is experiencing a leak, displaying a flashing light or any other fault, our maintenance technicians have the skills and qualifications to assess the situation and respond accordingly. As ZIP approved supply partners, we are highly experienced in examining faulty systems, proposing reparation or maintenance solutions which are appropriate and cost-effective. From troubleshooting to getting the issue resolved, you can call on OvoGard™.

Part replacement & boiler supply:

As approved and certified ZIP Supply partners, we repair, replace and supply brand new boiler and hot tap system units and their components. Part replacements are available at a typically cost-effective rate. Where modified, personalised systems are required, the OvoGard™ team can work with site architects to follow orders through until completion.



Sectors We Work With



Education

OvoGard™ promotes health and safety whilst reducing distribution needs across all educational environments, whether that's by using our innovative Secura systems or by using our bespoke design service.



Prisons & Policing

We understand that prisons, holding centres and custody suites face unique challenges in shielding essential, shared equipment. Our Shields provide cost-effective defense wherever it's needed. Systems like SecuraFlo™, SecuraBin™ and SecuraFire™ provide a virtually indestructible layer of protection, with their anti-climb, anti-ligature and anti-stash features ensuring that all service users access resources safely and responsibly.



Healthcare

We work with hospitals, mental health providers, health clinics and rehabilitation centres to ensure that staff and service users alike can access resources safely and responsibly. As a family-run business, we take the time to assess the needs of your health provision environment, with our staff attending during the installation process and on an ongoing basis to ensure the highest levels of safety for patients and staff alike with minimal disruption.



Industry

Heavy industry often plays host to fast-paced environments that are fraught with health & safety concerns. OvoGard™ protects infrastructure from accidental damage; whether that is through equipment failure or vehicle collisions.



The Old Fire Station, Argyle St,
Hazel Grove, Stockport, Cheshire, SK7 4ET

0161 401 0400

info@ovogard.com

ovogard.com